



300 Old Pretoria Road Albany, GA 310721
Phone: 229-883-1440 Fax: 229-439-9790
www.thrushaircraft.com

CUSTOM KIT

CK-AG-47

Initial Release: 02/28/2019

Whelen OR650 Series LED Wingtip Position/Anti-Collision
Light Assembly and Whelen 71544 Series LED Aft Position
Light Assembly

AIRPLANES AFFECTED:

<u>MODEL</u>	<u>SERIAL NUMBERS</u>
S2R-H80	ALL
S2R-T34	ALL
S2RHG-T34	ALL
S2R-T660	ALL
S2R-G10	ALL
S2RHG-T65	ALL

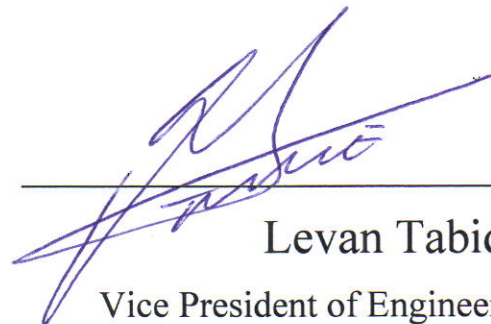
A handwritten signature in blue ink, appearing to read "Levan Tabidze", written over a horizontal line.

Levan Tabidze

Vice President of Engineering

LOG OF REVISIONS

NOTE: Reformatting and correction of typographical errors is not considered revision. True revisions are indicated by a dark vertical line at the right margin of the lines revised.

Rev.	Page	Description of Revision	By:
IR	All	New Document Initial Release.	K. Sheppard 02/28/2019

CONTENTS

1. PURPOSE/REASON FOR PUBLICATION:	3
2. SCOPE/COMPLIANCE:	3
3. BY WHOM WORK WILL BE ACCOMPLISHED:.....	3
4. APPROVAL:	3
5. MAN HOURS:.....	3
6. SPECIAL TOOLS:	3
7. PARTS LIST.....	3
8. ACCOMPLISHMENT INSTRUCTIONS:.....	4
9. RECORD OF COMPLIANCE:	13
10. RESPONSE CARD	13

1. PURPOSE/REASON FOR PUBLICATION:

This Custom Kit provides instructions and parts for the installation of the Whelen OR650 series LED wingtip position/anti-collision light assembly and 71554 series LED aft position light assembly on Thrush models S2R-H80, S2R-T34, S2R-G10, S2RHG-T65, and S2R-T660.

2. SCOPE/COMPLIANCE:

This Custom Kit is recommended for Thrush models S2R-H80, S2R-T34, S2R-G10, and S2R-T660.

3. BY WHOM WORK WILL BE ACCOMPLISHED:

The work is to be accomplished by a FAA Certified A&P mechanic or foreign equivalent.

4. APPROVAL:

This Custom Kit is approved by the Vice President of Engineering at Thrush Aircraft, Inc.

5. MAN HOURS:

2 hours will be required.

6. SPECIAL TOOLS:

No special tools required.

7. PARTS LIST

QUANTITY	PART NUMBER	DESCRIPTION
1	339710003-001	Position/Anti-Collision Light Harness L/H
1	339710003-002	Position/Anti-Collision Light Harness R/H
1	7155402	LED Tail Position Light Assembly
6	NASM24693-C250	Screw, Machine, C'Sunk Head
6	NAS1149FN632P	Washer
6	MS21044N06	Nut
2	1-480-271-0 MALE	6 Pin Connector
2	1-480-270-0 FEMALE	6 Pin Connector
1	1-480-318-0 FEMALE	2 Pin Molex Connector
1	1-480-319-0 MALE	2 Pin Molex Connector
20	60620-1	Male Pin
20	60619-1	Female Pin

8. ACCOMPLISHMENT INSTRUCTIONS:

NOTE: All photos shown are on 510G model. All installations are the same for all models.

1. Disconnect aircraft batteries.

For removal of wingtip navigation lights and installation of new wingtip navigation lights:

2. Remove the inspection plates and wingtip NAV light plate shown in Figure 47-1 and 47-2.

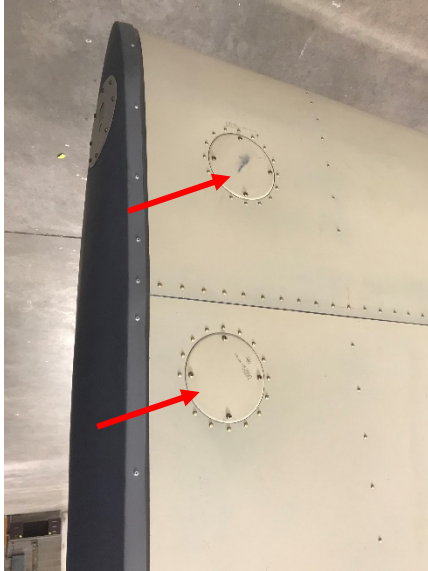

Figure 47-1
Inspection Plates



Figure 47-2
Wingtip Navigation Light

3. Remove wingtip NAV light A 650 PR 28 (L/H) and A 650 PG 28 (R/H) from plate by removing screw (1) on outside cover, sliding the light cover off, then removing screws (3) from plate. See Figure 47-3 and 47-4.

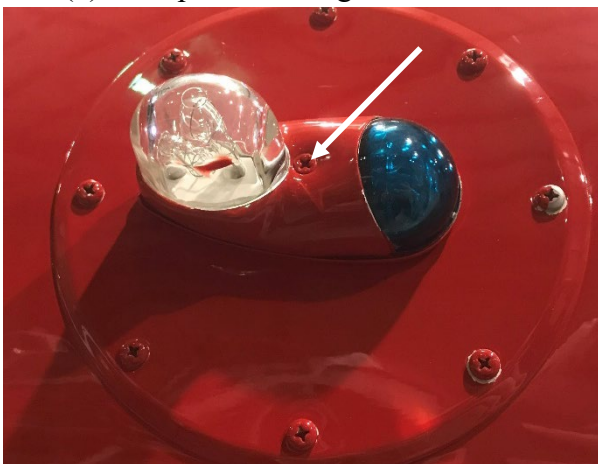

Figure 47-3
Wingtip Navigation Light Removal

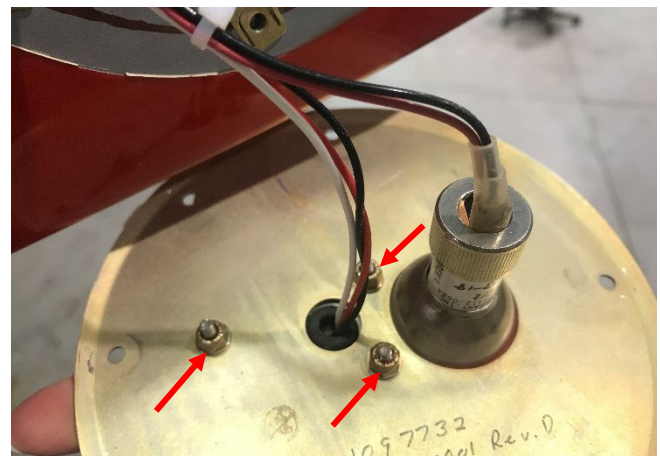

Figure 47-4
Wingtip Navigation Light Removal

4. Take top quick disconnect from power supply and disconnect wires 29043-039A-18 and 29043-041-18 (R/H) and 29043-039B-18 and 29043-040-18 (L/H). Take bottom quick disconnect from power supply and remove wire 29043-081-18 (L/H) and 29043-080-18 (R/H).

CAUTION

Do NOT remove knife splice to wire 29043-498-18 (L/H) and 29043-499-18 (R/H). This is needed to have enough slack.

Disconnect ground wires 29043-487-18 (R/H) and 29043-486-18 (L/H). All wires are labeled with their correct part number. See Figure 47-5.

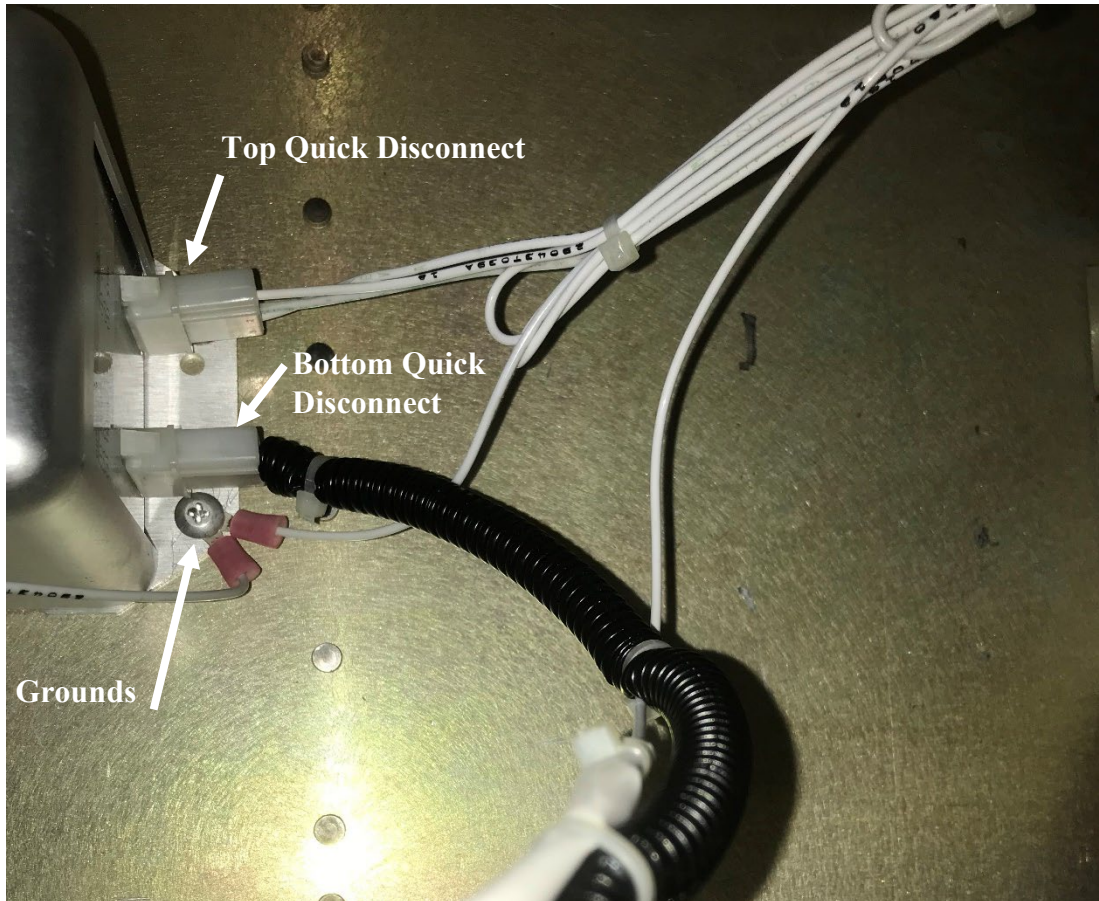

Figure 47-5
Power Supply Connections

5. Remove power supply from inside of wingtip by removing screws (4) and discard. See Figure 47-6.

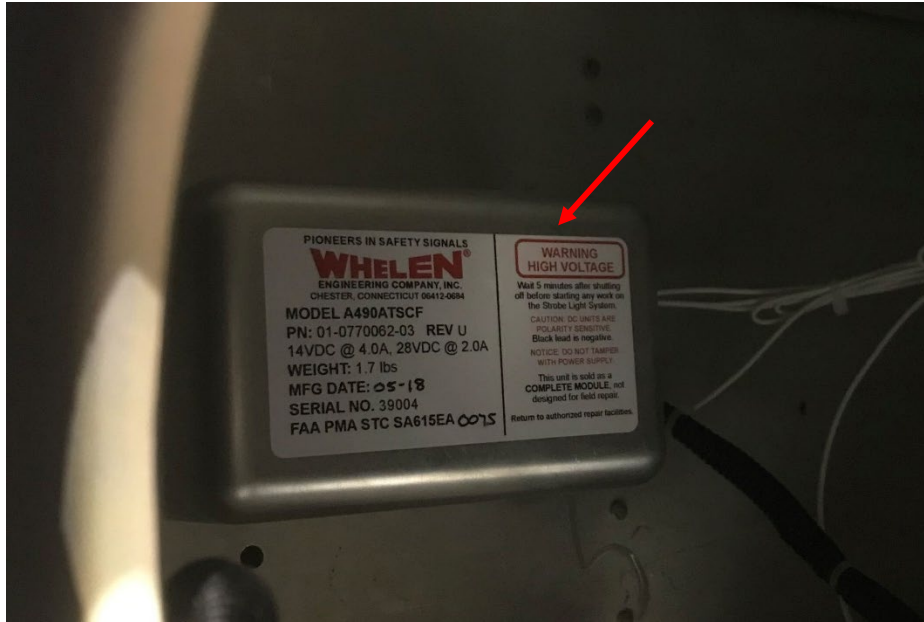
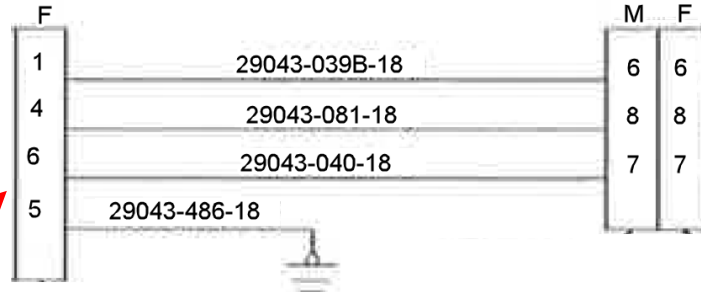
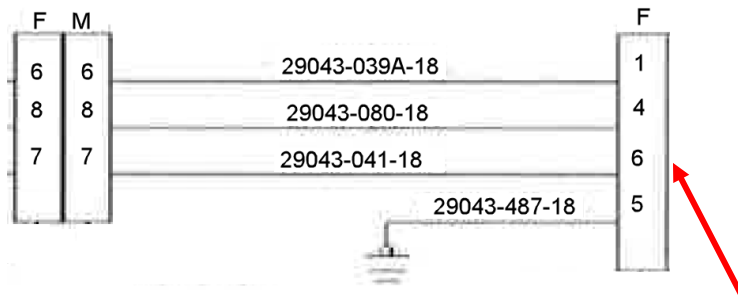

Figure 47-6
Power Supply

6. Add wires 29043-039B-18, 29043-040-18, 29043-081-18, 29043-486-18 (L/H) and 29043-039A-18, 29043-041-18, 29043-080-18, 29043-487-18 (R/H) to a female 6-pin connector. Reconnect wire 29043-486-18 (L/H) and 29043-487-18 (R/H) to original ground location. See Figure 47-7 and 47-8.



Female 6-Pin Connector
Figure 47-7
Wiring Schematic



Female 6-Pin Connector
Figure 47-8
Wiring Schematic

7. Install new Whelen LED light 339710003-001 (L/H) and 339710003-002 (R/H) in same location as the old light. Use the following instructions and Figure 47-9:
 - a) Carefully remove the #4 phillips head screw and lens retainer. Remove the lens from the light assembly by lifting the rear of the lens approximately 1/2". Now slide the lens rearward approximately 1/4" and lift upwards to remove.

CAUTION

To avoid potential damage, do not touch the LEDs with either fingers or sharp objects.

- b) Remove the 3 Phillips head screws securing the baseplate to the light assembly. Remove baseplate.
- c) Using the (3) NASM24693-C250 screws, NAS1149FN632P washers, and MS21044N06 nuts, install the baseplate directly to the aircraft inspection plate.
- d) Route the wires through the opening in the baseplate.
- e) Re-install the light assembly on to the baseplate and insure that all leads are clear of any obstructions and secured as required. Note that proper orientation is achieved with the drain hole down.
- f) Install lens in the reverse order as removal and return the lens retainer to its installed location. Note: Visually confirm that the lens and retainer are fully and properly seated. Re-insert #4 phillips head screw and tighten firmly.

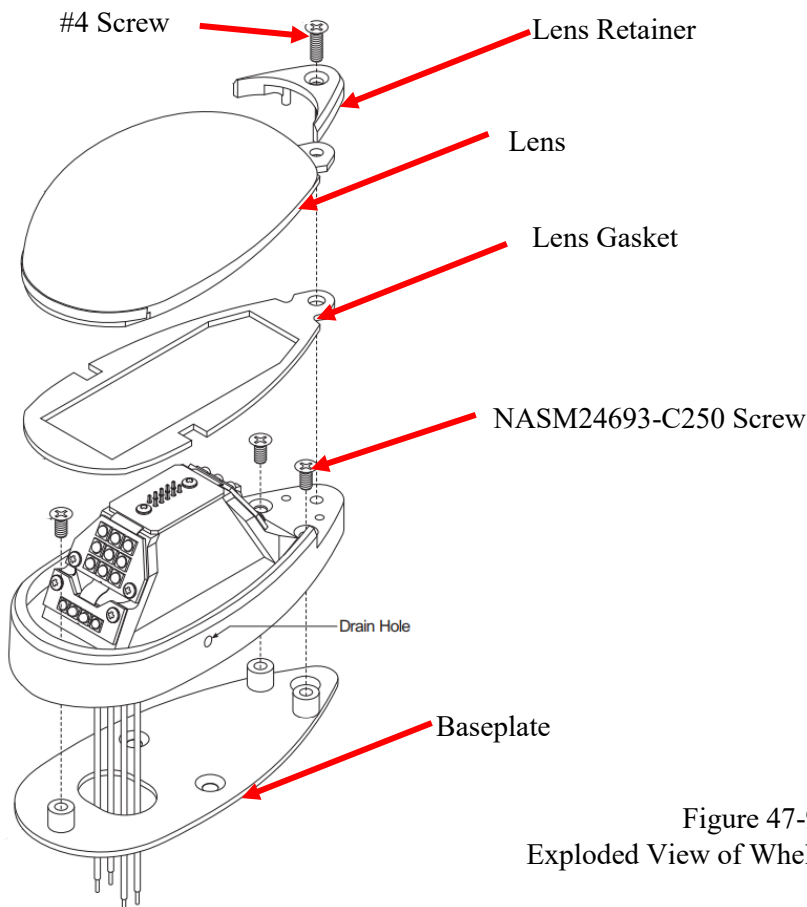

Figure 47-9
Exploded View of Whelen LED Light

- Install the white, orange, yellow, and black wires to a male 6-pin connector coming from LED light. Connect the female 6-pin connector to the male 6-pin connector. See Figures 47-10 and 47-11.

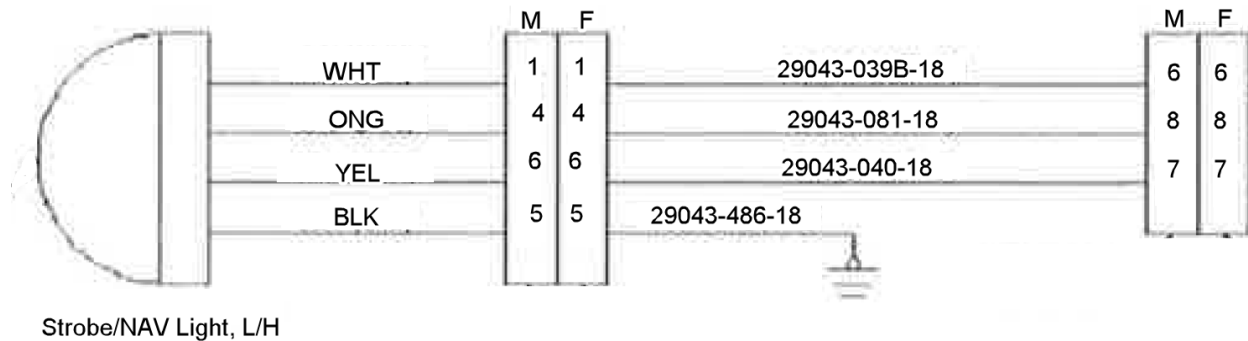

Figure 47-10
Wiring Schematic

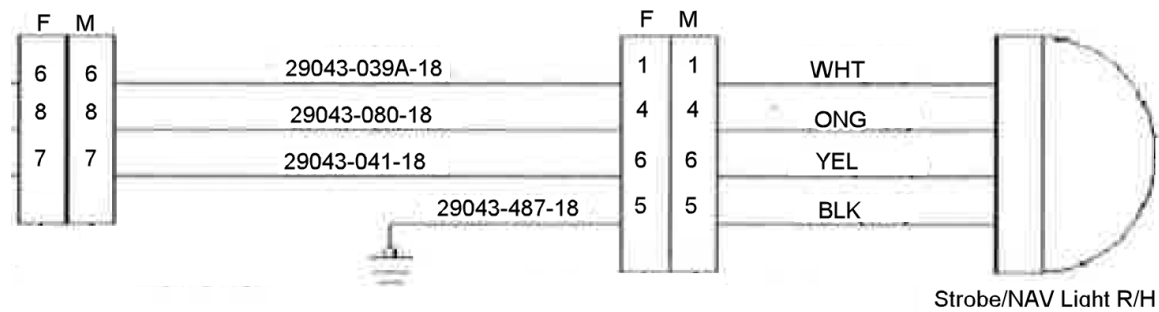

Figure 47-11
Wiring Schematic

- Reinstall wingtip inspection plates. Reuse hardware.

For removal of tail light assembly and installation of new tail light assembly:

10. Remove light from aircraft by removing (2) screws. See Figure 47-12.

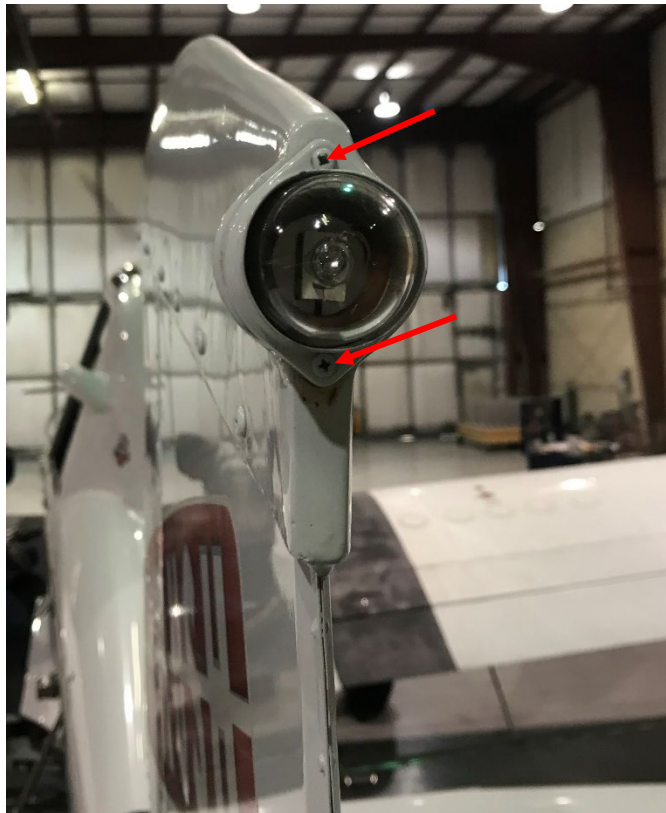

Figure 47-12
Tail Light Assembly

11. Remove knife splices on wires 29043-077A-18 and 29043-079-18. See Figure 47-13.

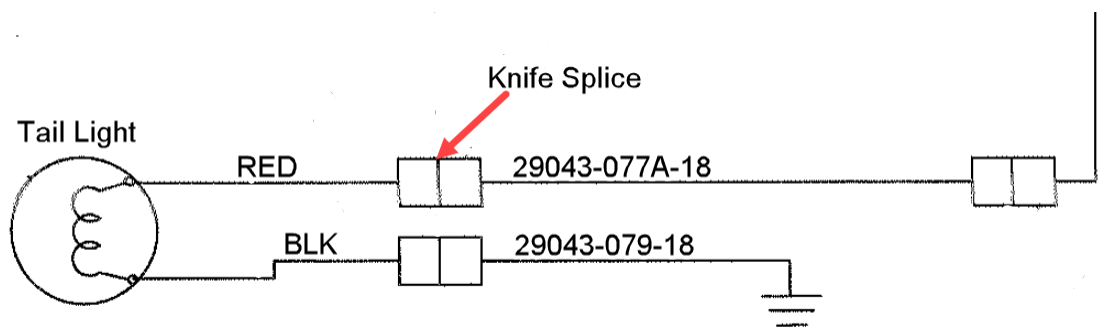

Figure 47-13
Wiring Schematic

12. Add wires 29043-077A-18 and 29043-079-18 to a female 2-pin connector. See Figure 47-14.

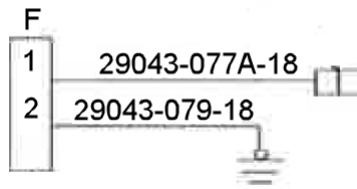

Figure 47-14
 Wiring Schematic

13. Add WHT and BLK wires connected to tail light 7155402 to a male 2-pin connector. Connect male 2-pin connector to female 2-pin connector. See Figure 47-15.

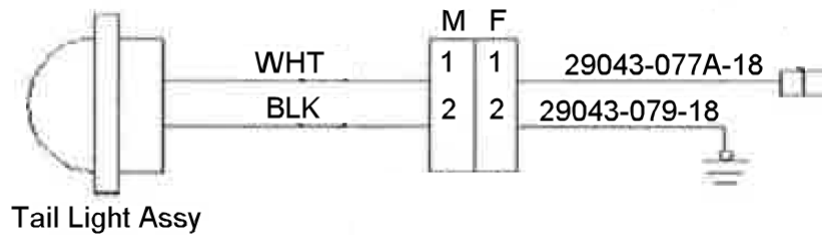

Figure 47-15
 Wiring Schematic

14. Attach Whelen LED light 7155402 to previous location. See Figure 47-16.
 - a) Remove the two screws and nuts holding the retainer to the unit. Carefully remove the lens retainer and lens from the assembly.

CAUTION

To avoid potential damage, do not touch the LEDs with either fingers or sharp objects.

- b) Install light assembly and insure that all leads are clear of any obstructions.
- c) Reinstall the lens and confirm proper gasket fit.
- d) Install the lens retainer using existing screws. Seal using sealant CS3204B2.

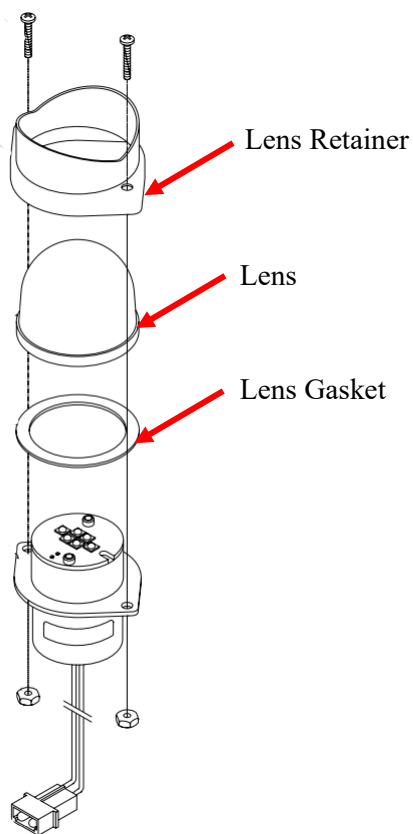

Figure 47-16
Exploded View of Whelen LED Tail Light

15. Reconnect aircraft batteries. Check for functionality.

9. RECORD OF COMPLIANCE:

Make appropriate entry in airplane maintenance records as follows:

“Thrush Custom Kit CK-AG-47 Rev. IR complied with at _____ total hours on aircraft.”

Modification accomplished by:

Name & Certificate #	Date
----------------------	------

10. RESPONSE CARD

The final step in compliance with this Custom Kit is to complete and return the compliance card on the next page. It may be mailed, Faxed, or scanned and e-mailed.

Fax to:	Ed Rusk	229-439-9790
Email to:	Ed Rusk	erusk@thrushaircraft.com

Custom Kit CK-AG-47 Rev. IR Compliance Report

Aircraft S/N:	Aircraft Owner:
Aircraft Registration #:	Address of Owner:
Airframe total time:	City & State:
Engine total time:	Physical location:
Complied with by:	Date of Compliance:
Signature:	Certificate #:

PLEASE RETURN THIS REPORT ONLY AFTER MODIFICATION IS MADE

This response card may be mailed, faxed to (229) 439-9760, or emailed to erusk@thrushaircraft.com.

Fold, Tape & Mail (Do Not Staple)

Return Address

Thrush Aircraft Inc.
Attn: Ed Rusk
300 Old Pretoria Road
Albany, Ga 31721